

# Cambelt

Low Profile SELF PROPELLED Railcar Unloaders

Featuring Cambelt's Extraordinary  
CamFlex  
Fully Molded Flexible Sidewall Belt

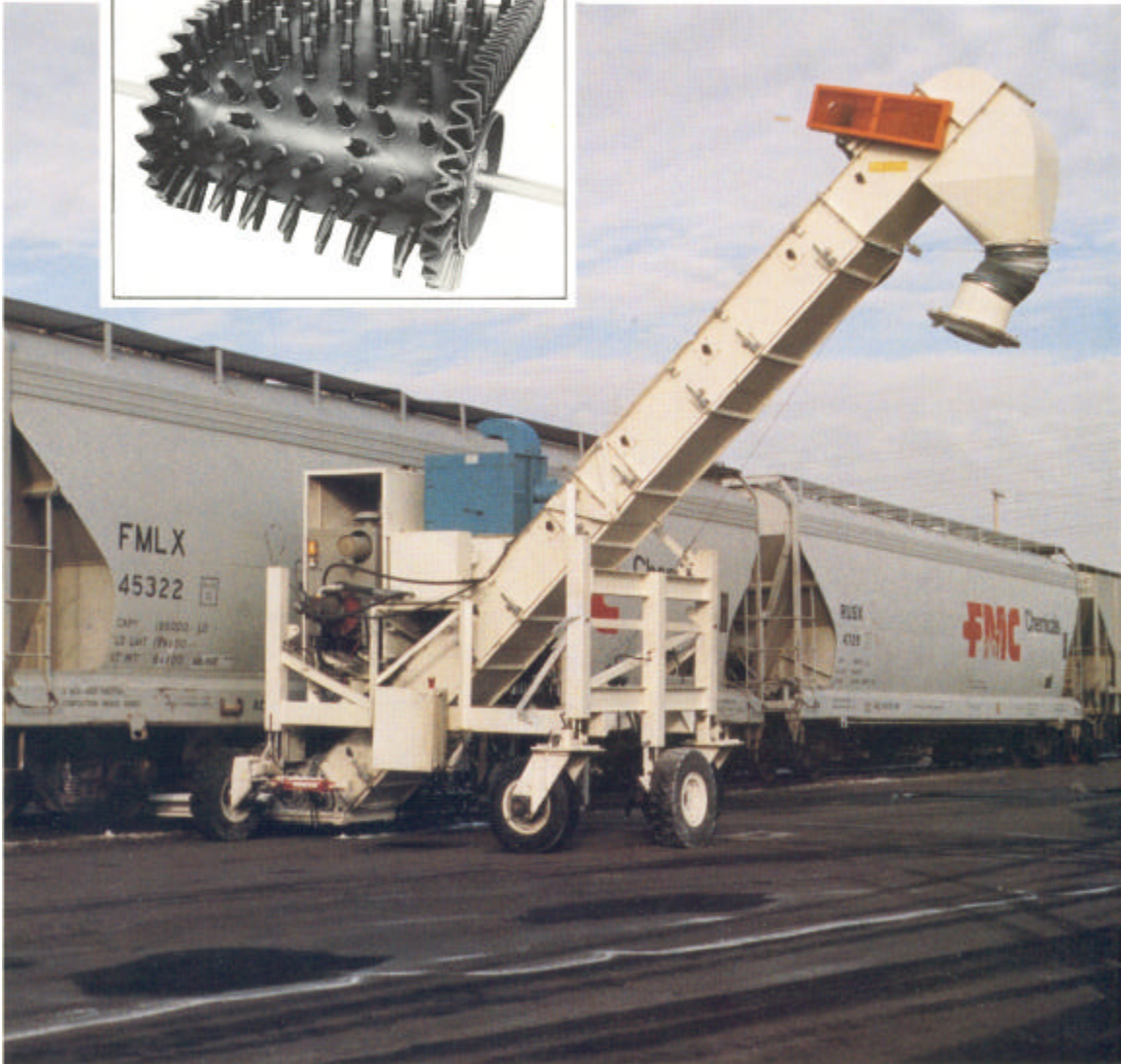
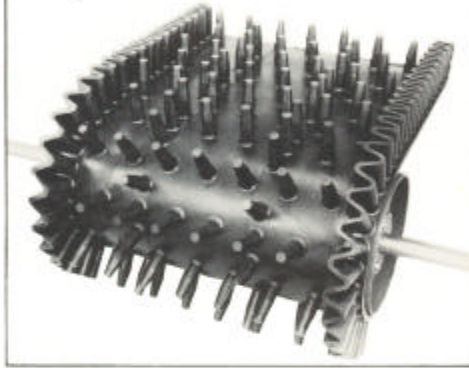

## CAPACITY CHART

### Model SPCF2420

Belt Speed	300 FPM			400 FPM			500 FPM		
Weight of material in lb/FT squared	60#	80#	100#	60#	80#	100#	60#	80#	100#
Capacity - tons per hour	73	97	122	97	130	162	122	162	203

## SPECIFICATIONS

### Power Options

Electric / Hydraulic – 480 Volt TEFC 3 phase 60 cycle.

Conveyor belt drive 20 HP

Hydraulic pump drive 7.5 HP

Diesel / Hydraulic

Diesel Engine - 4-cylinder turbo-charged engine.

Hydraulic Pumps

Conveyor Drive – 34 GPM 2500 PSI

Powered Wheels – 10 GPM 2500 PSI

Electric Generator – 4 RVA 120 / 240 V 1 phase 60 cycle.

(For flood lights & dust collector motor)Running ar

### Running Gear

Hydraulic Drives Hydraulic Motors coupled to planetary gear reducer

Drive Wheels (3) 8.25-15 12 ply mining service tires

Swivel Wheels (2) 7.50 – 16 10 ply Load Range E Tirs

### Controls

Steering – Complete 360 degree turn within vehicle length.

Forward –reverse & lateral movement

Height adjustment – 0” to 23”

### Special Features

Dust Control System

Hydraulic Car Vibrator

Custom inlet configurations

Flood lights for night operation.

Shown are theoretic capacities based on a dry, free flowing material with a steady continuous feed of material to the belt. Flowability, particle size, moisture content, and method of feeding may affect actual capacity rates.

Cambelt’s patented and proven equipment using our own fully molded CamFlex belting offers many advantages in both cost and operation. Take a look at what the Cambelt alternative can offer you; higher capacities, lower horsepower, less product degradation, fewer dust control problems, and lower costs – and that means all costs..equipment costs, operating costs, and maintenance costs.

CamFlex and CamWall fully molded flexible sidewall belts are the only flexible sidewall belts that are unconditionally guaranteed against delamination of the sidewall from the base belt. They don’t come apart.

For both high quality and a good price, come to Cambelt.

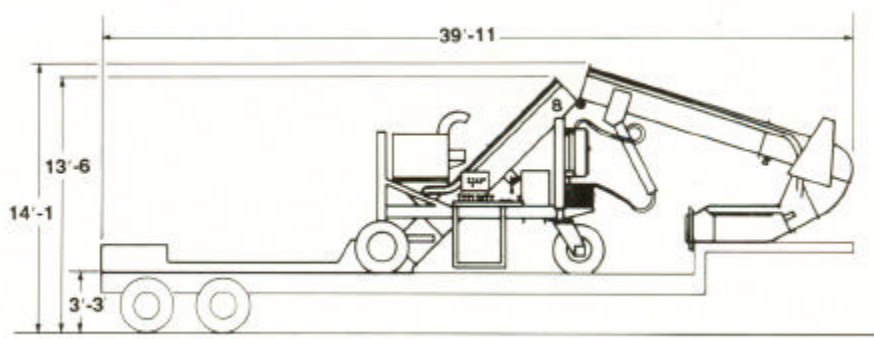
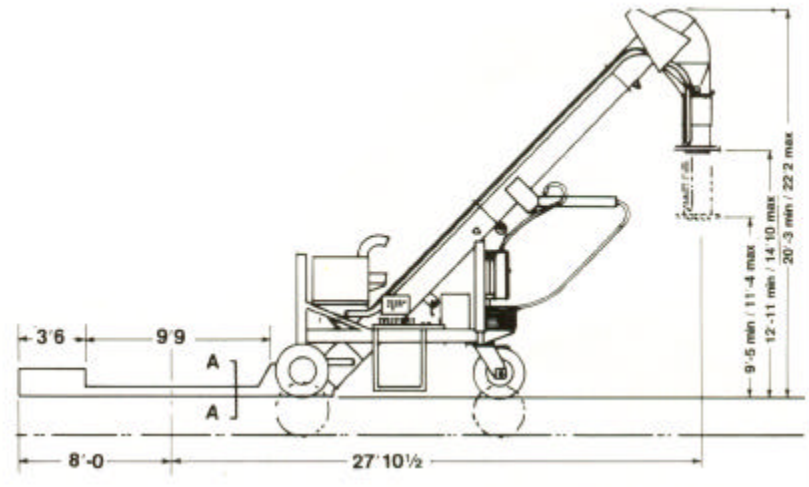
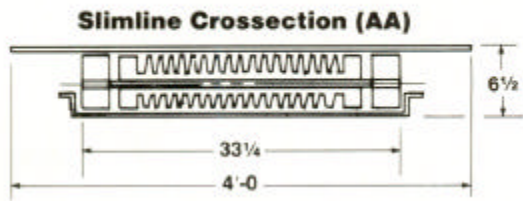
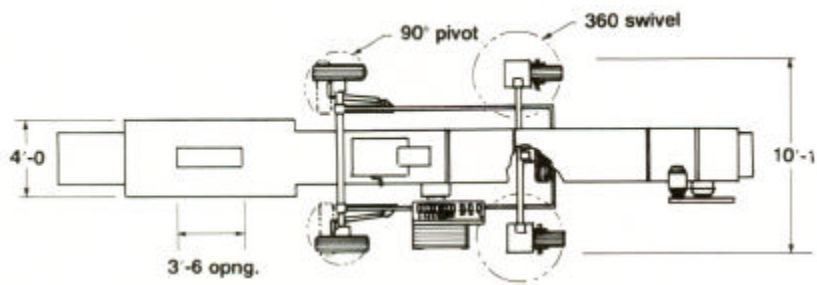

**Conveyor Breakdown for Lowboy Transporting**